

Homework No. 08 (Spring 2022)

PHYS 203B-001: COLLEGE PHYSICS

Department of Physics, Southern Illinois University–Carbondale

Due date: Wednesday, 2022 Mar 30, 10:00am, on D2L

Instructions

- To the extent to which you depend on resources to complete this homework is a measure of how much extra work you need to put in to master the related concepts.
- Describe your thought process in detail and organize it clearly. Make sure your answer has the correct units and the right number of significant digits.
- After completion, scan the pages as a single PDF file, and submit the file on D2L (Assessments → Assignments).

Problems

1. **(10 points.)** An elastic conducting material is stretched into a circular loop of 15 cm radius. It is placed with its plane perpendicular to a uniform 0.50 T magnetic field. When released, the radius of the loop starts to shrink at the rate of 72 cm/s.
 - (a) What is the direction of the induced current?
 - (b) What EMF is induced in the loop?

Solution

2. **(10 points.)** Figure 1 shows a conducting rod being pulled along horizontal, frictionless, conducting rails at a constant speed v . A uniform magnetic field \mathbf{B} fills the region in which the rod moves. Assume $L = 10.0$ cm, $v = 5.0$ m/s, $B = 1.2$ T, and $R = 0.40$ Ω .
 - (a) Is the magnetic flux in the loop increasing or decreasing?
 - (b) What is the direction of the induced current in the loop?
 - (c) Determine the magnitude of the induced current in the loop.

Solution

3. **(10 points.)** Figure 2 shows five snapshots of a rectangular coil being pushed across the dotted region where there is a uniform magnetic field directed into the page. Outside of this region the magnetic field is zero. Determine the direction of induced current in the loop at each of the five instances in the figure. Given $L = 10.0$ cm, $v = 5.0$ m/s, and $B = 1.2$ T, determine the induced EMF in the loop at each of the five instances in the figure.

Solution

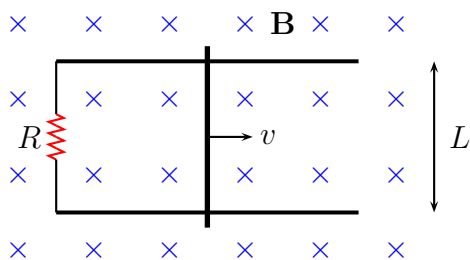

Figure 1: Problem 2

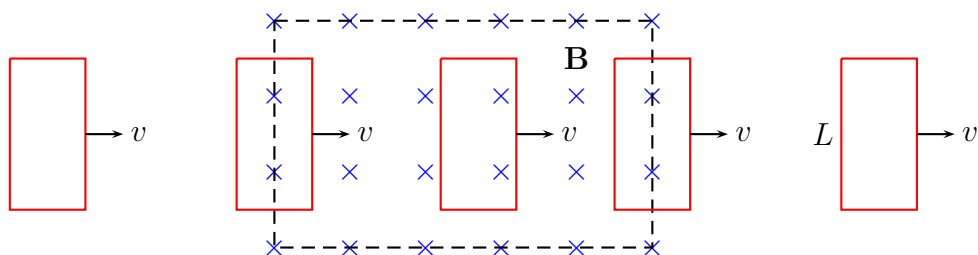

Figure 2: Problem 3.

4. (10 points.) A transformer consists of two coils wound on the same cylinder such that the flux through both the coils is the same, that is,

$$\frac{\Delta\Phi_1}{\Delta t} = \frac{\Delta\Phi_2}{\Delta t}. \quad (1)$$

Thus, using Faraday's law derive the ratio of the voltages in the two coils to be given by

$$\frac{V_1}{V_2} = \frac{N_1}{N_2}. \quad (2)$$

Energy conservation requires the power in the coils to be the same, that is $P_1 = P_2$. Thus, further derive

$$\frac{I_2}{I_1} = \frac{N_1}{N_2}. \quad (3)$$

A device operates at $V_2 = 10.0\text{ V}$. It uses a transformer to get the required voltage when plugged into a wall socket with voltage $V_1 = 120\text{ V}$.

- Determine the ratio of the turns in the two coils inside the transformer.
- If the device pulls a current of 120 mA, determine the current coming out of the wall socket.

Solution

5. (10 points.) Consider the area enclosed by the loop formed in the configuration shown in Figure 3. The rotation described in the figure effectively changes the area enclosed by the loop periodically.

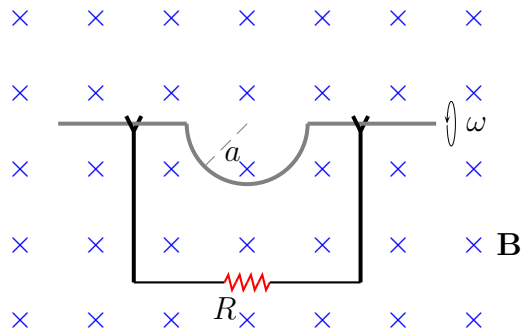

Figure 3: Problem 5

- (a) For uniform angular speed of rotation ω , with $\theta = \omega t$, use the identity

$$\frac{\Delta \cos \theta}{\Delta t} = -\omega \sin \omega t \quad (4)$$

to show that the induced EMF in the loop is given by

$$\Delta V_{\text{eff}} = BA\omega \sin \omega t. \quad (5)$$

Determine the maximum induced voltage for $B = 0.10 \text{ T}$, radius $a = 10.0 \text{ cm}$, and angular speed of rotation of 600 revolutions per minute ($\omega = 20.0\pi \text{ rad/s}$).

- (b) Qualitatively plot the induced voltage as a function of time.

Solution

6. (10 points.) A loop of wire having a resistance $R = 100.0 \Omega$ is placed in a magnetic field whose magnitude is changing in time, as described in Figure 4. The direction of the magnetic field is normal to the plane of the loop. The loop of wire consists of 50 turns and has an area of $A = 25 \times 10^{-4} \text{ m}^2$.

- (a) Determine the induced voltage and the induced current in the loop between 0 s to 2 s.
- (b) Determine the induced voltage and the induced current in the loop between 4 s to 5 s.

Solution

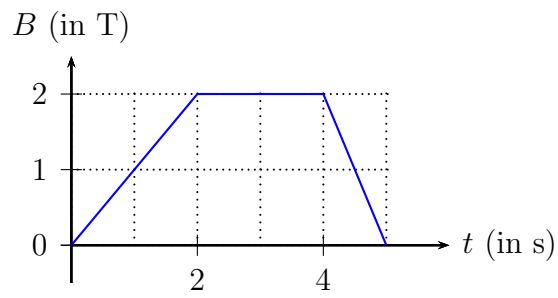

Figure 4: Problem 6.